

REV.	ECN.NO.	MODIFY.CONTENT	DATE
A		NEW	2012/04/13

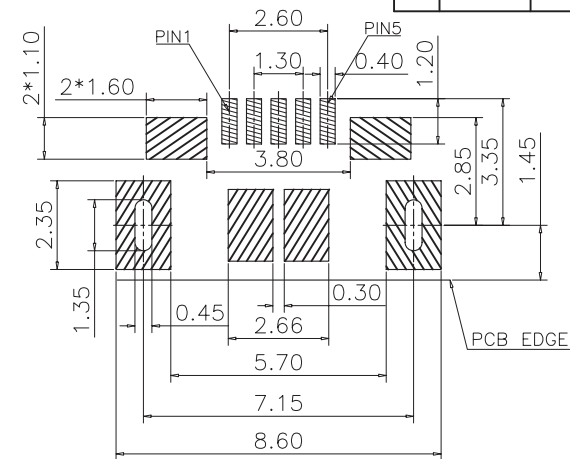
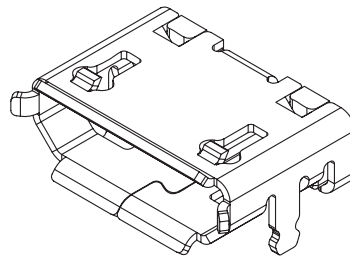
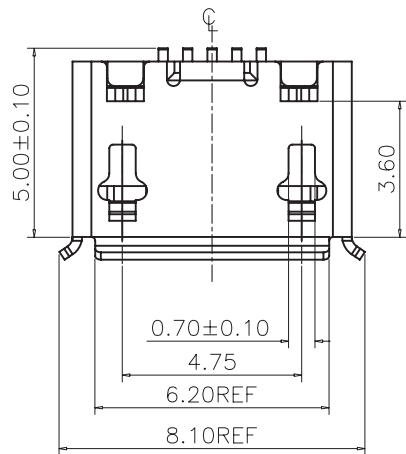

RECOMMENDED PCB LAYOUT(TOP VIEW)
GENERAL TOLERANCES:±0.05

NOTES:

SPECIFICATIONS:

- VOLTAGE RATING:100V AC
 - CURRENT RATING:1.0A
 - INSULATION RESISTANCE:100MEG.OHM MIN
 - contact resistance:50 mill.ohm MAX
 - OPERATION TEMPERATURE:-20°TO+65°
 - INSERT FORCE:35N MAX
 - EXTRACT FORCE:8N MIN
 - DURABILITY:10000CYCLES
 - INSERT FORCE AND EXTRACT FORCE AFTER10000CYCLES IS FIT FOR THE USB SPECIFLICATION.
 - DIMENSIONS WITH MARK"*"MUST BE MEASURE BY QC AND IPQC.
- MATERIAL:
- HOUSING :LCP+30%G/F (UL94V-0)
 - TERMINAL:COPPER ALLOY;T=0.15mm
Au 1u"PLATING ON CONTACT area,G/F PLATING
ONSOLDERTAILS,50u" Min Ni UNDERPLATING OVER ALL.
 - SHELL:SUS304-1/2H;T=0.25mm
1u"AU PLATING ON SOLDERTAILS,50u"MIN,Ni UNDERPLATING OVER ALL.

PART NUMBER INFORMATION :

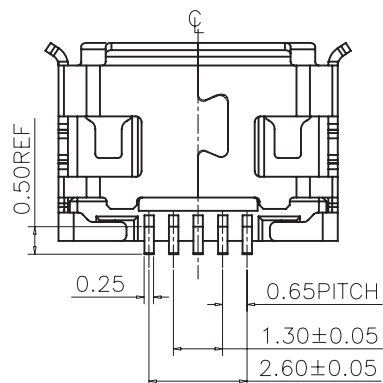
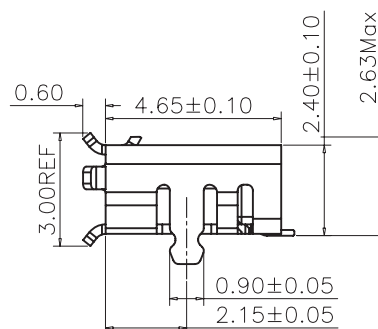
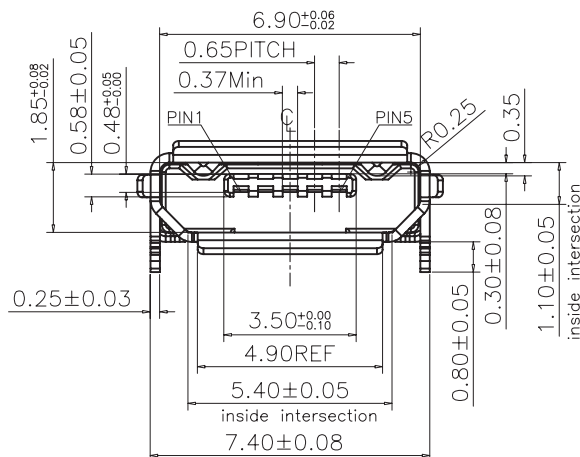
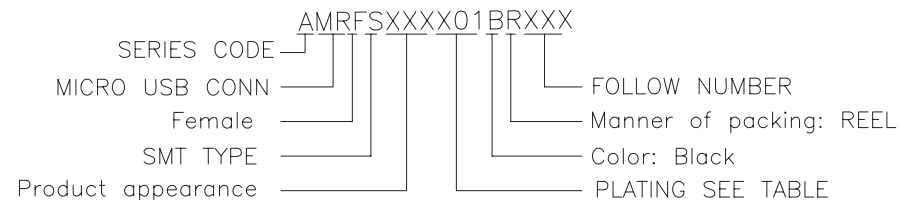

GENERAL TOLERANCE		DWG NO.	LZA0413-04	APPD:	WIND	Scale	1:1
X.±0.45	x.*±5°	Title	MICRO USB 5P SMT B TYPE WITHOUT POST (7.15)	CHKD:		UNIT	mm
.X±0.35	.x.*±2°			DR:			
.XX±0.25	.xx.*±1°	Part NO.	AMRFS715A01BR008	Date	2012/04/13		
.XXX±0.15	.xxx.*±0.5°						
SHEET	1/1	东莞市汉硕电子科技有限公司					

REV.	ECN.NO.	MODIFY.CONTENT	DATE
A		NEW	2012/04/13

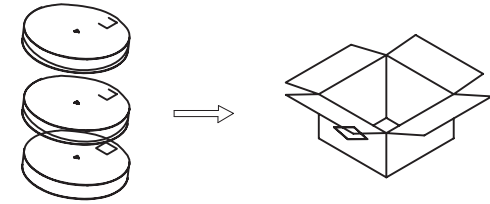
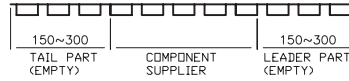
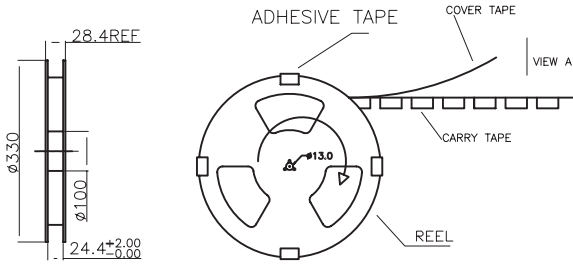

每箱装12盘, 依次叠在一起(图一)

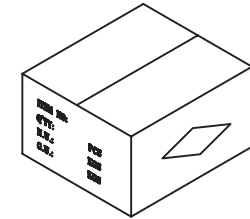

封箱, 填写相关内容(图二)

对应三视图

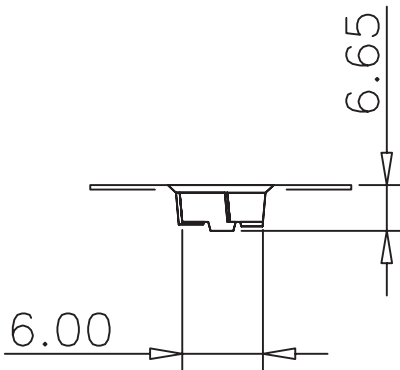
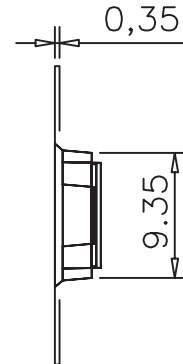
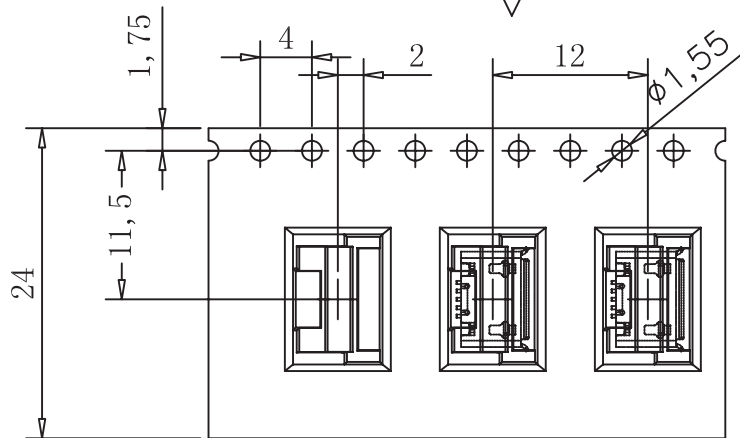

NOTE:

1. CARRY TAPE(黑色)前部分与尾部分各留出150~300mm长度不装产品
2. 每穴放置1PCS产品, 放置方式如图所示
3. 包装机包好后, 在REEL的个等分点贴上胶带, 以防止REEL张开, 每REEL贴1PCS标签
4. 包装数量: 1500PCS/REEL, 12REEL/CARTON, 18000PCS/CARTON
5. 依次将产品放入箱内, 共放12盘(图示一)
6. 封箱, 在封好的纸箱上按客户要求写上料号, 数量等(图示二)
7. 顺向出料, 单孔朝外。
8. 顺向出料, 双孔按图示三

GENERAL TOLERANCE		DWG NO.	LZA0414-01	APPD:	WIND	Scale	1:1
X.±0.45	x.*±5°	Title	MICRO USB 5P SMT B TYPE WITHOUT POST (7.15)包装图	CHKD:		UNIT	mm
.X±0.35	.x.*±2°			DR:			
.XX±0.25	.xx.*±1°	Part NO.		Date	2012/04/13		
.XXX±0.15	.xxx.*±0.5°						
SHEET	1/1	东莞市汉硕电子科技有限公司					